

Magnetic Sweepers and Pickup Tools

Magnetic Sweeper w/o Quick Release

Part No. 600
Part No. 601

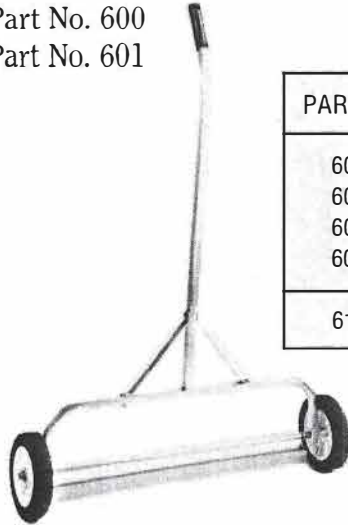

Magnetic Sweeper w/Quick Release

Part No. 618

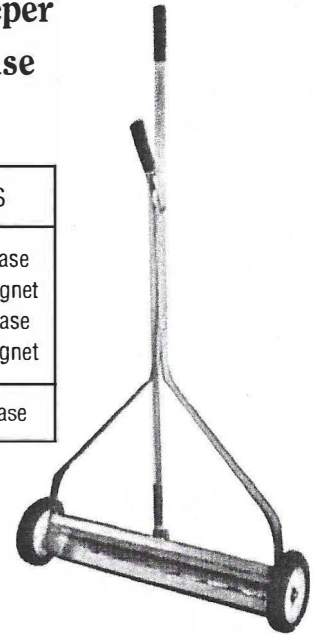

PART NO.	WIDTH	SHIPPING WEIGHT	COMMENTS
600	24"	9 LBS.	W/O Quick Release
602	24"	-	Replacement Magnet
601	36"	13 LBS.	W/O Quick Release
603	36"	-	Replacement Magnet
618	24"	27 LBS.	with Quick Release

• CUSTOM WIDTHS MADE ON REQUEST •

Magnetic T-Bar Sweeper

Part No. 604
Part No. 610
Part No. 611

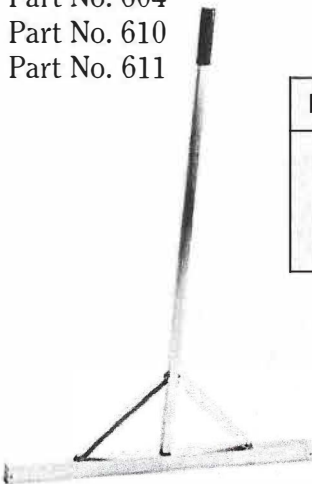

PART NO.	WIDTH	SHIPPING WEIGHT	COMMENTS
604	14"	6 LBS.	Magnetic T-Bar
610	24"	8 LBS.	
611	36"	11 LBS.	

Forklift Magnets

- Easily installs under any front bumper or lift truck using eye hooks supplied and two short lengths of chain.
- Constructed of highest quality materials and permanent magnets that are guaranteed for life.

STANDARD DUTY

PART NUMBER	SIZE	APPROXIMATE WEIGHT
82007	2 x 4 x 36	45 LBS.
82008	2 x 4 x 48	60 LBS.
82009	2 x 4 x 60	75 LBS.
82010	2 x 4 x 72	90 LBS.

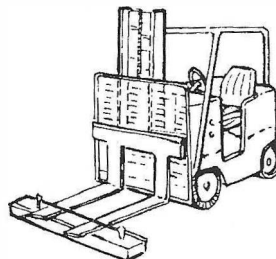

HEAVY DUTY

PART NUMBER	SIZE	APPROXIMATE WEIGHT
82011	2 x 6 x 36	60 LBS.
82012	2 x 6 x 48	80 LBS.
82013	2 x 6 x 60	100 LBS.
82014	2 x 6 x 72	120 LBS.

Industrial Grade Holding Magnets

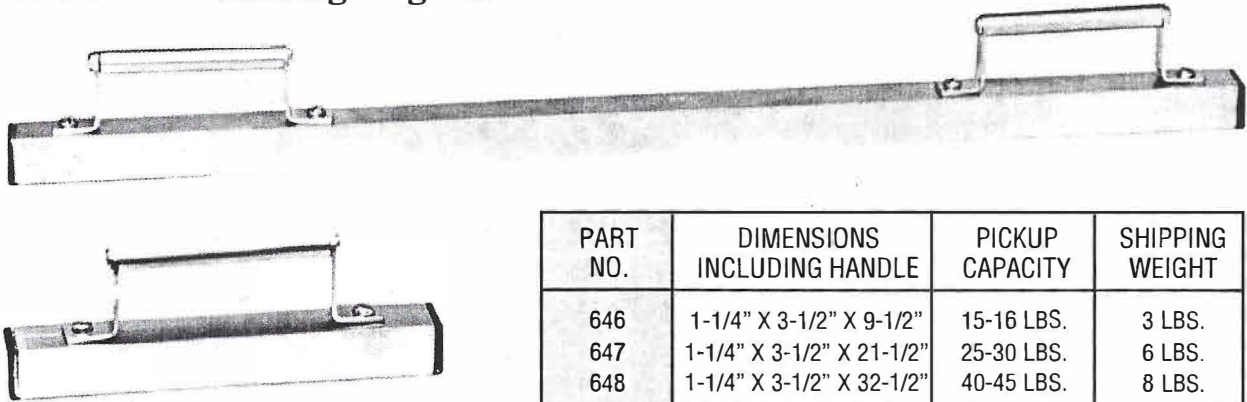

PART NO.	DIMENSIONS INCLUDING HANDLE	PICKUP CAPACITY	SHIPPING WEIGHT
646	1-1/4" X 3-1/2" X 9-1/2"	15-16 LBS.	3 LBS.
647	1-1/4" X 3-1/2" X 21-1/2"	25-30 LBS.	6 LBS.
648	1-1/4" X 3-1/2" X 32-1/2"	40-45 LBS.	8 LBS.

Key Chain Magnet

3/8" diameter · 2-1/4" long

Part No. 614

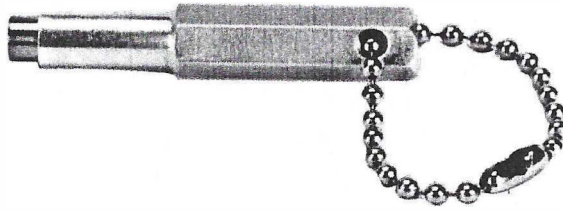

Pocket Pick-Up Magnet

5" length with pocket clip.

Part No. 615



Please call for quotes on custom magnets